

HAITIAN INTERNATIONAL HOLDINGS LIMITED

Unit 1105 Level 11
Metroplaza Tower 2
223 Hing Fong RD Kwai Fong N.T
haitian@mail.haitian.com
www.haitian.com

NINGBO HAITIAN HUAYUAN MACHINERY CO., LTD.

No.1, Nanhuan Road, Export Processing Zone, Beilun, Ningbo, Zhejiang, 315806 P.R. China
+86-574-86177242
+86-574-86221864
haitian@mail.haitian.com
www.haitian.com

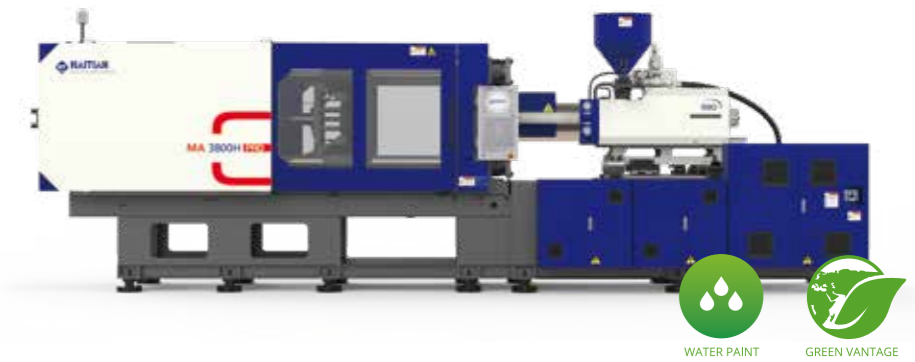

MA/H PRO

Injection Molding Machinery for Fast cycle applications

2,100-4,500kN

HT 20230512-IV



More Than 50 Years of Manufacturing Experience

We Create Advantage

Industry Trends

For plastic products, customers expect a variety of choices, excellent quality and reasonable prices. In order to be competitive in the packaging industry, plastics manufacturers must achieve low costs and short cycle times while ensuring strict product quality standards.

Plastics packaging containers tend to be thin-walled to reduce cost and to meet environmental requirements. Therefore, faster injection speeds and mass production are the main characteristics of thin-wall plastic packaging. Haitian's persistent drive to optimize solutions in both mechanical engineering and forming technology enabled us to develop injection molding machinery with a higher cost to performance ratio in the packaging industry.

The Haitian MA/H PRO Series is designed for fast cycle applications in the production of thin-walled containers. Engineered to achieve the dual benefits of high efficiency and low cost to bring customers more profits in their pursuit of precision, high-speed and repeatability.

The high-speed MA/H PRO series is widely used in various fields of packaging products, such as beverage cups, yogurt cups, ice cream boxes, lunch boxes, bowls, crisper, cutlery, bottle caps, mobile phone battery covers, medical packaging, etc. The excellent performance and versatility of the MA/H PRO has proven itself across a wide range of packaging products and applications.

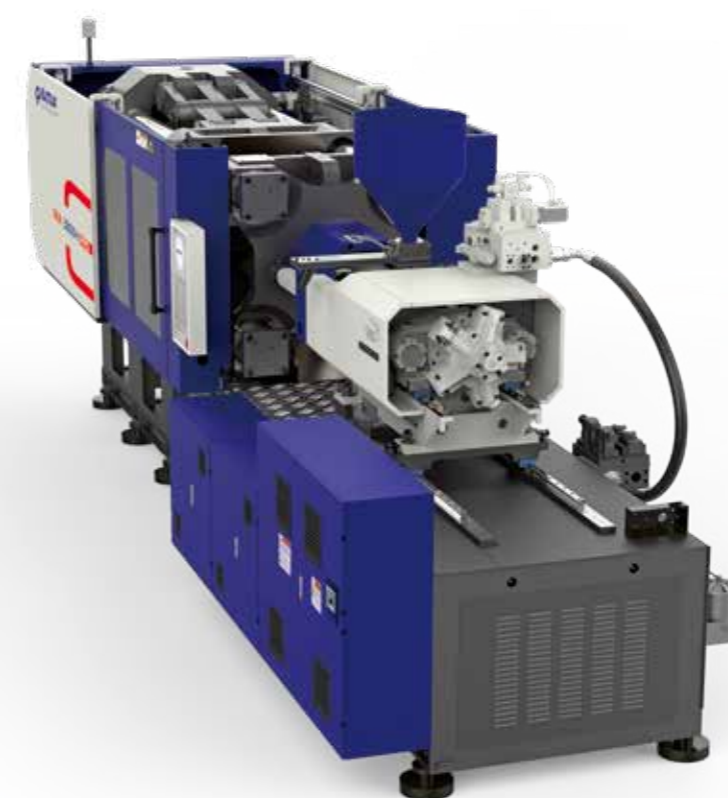

Advantages of MA/H PRO

- ◎ Quick response capability of injection
- ◎ High injection rate
- ◎ Stable and reliable injection structure
- ◎ High rigidity clamping mechanism
- ◎ Quick response capability of mold close
- ◎ Intelligent mold open/close control
- ◎ Special screw and barrel design

Applications



Food Packaging

The MA/H PRO provides a highly efficient and high-quality solution for the plastics packaging products in the fast-moving consumer goods industry. Our machinery can produce thinner, lighter products on a more consistent process. Such as fast food containers, beverage cups, ice cream boxes and disposable tableware, etc.



Pharmaceutical Packaging

For cylindrical products such as syringes and medicine bottles etc., accurate flow control is applied to ensure high quality standards.



Civil Product Packaging

In terms of thin-wall products with long flow length and even mixture, the MA/H PRO can meet the requirements for shorter cycle and long-term continuous production, while ensuring the high degree of process stability. Application cases include buckets, flower pots, storage boxes, etc.



Logistics Packaging

We provide more efficient application solutions for price-sensitive market segments, such as cable ties.

Excellent Performance

Overview of the Whole Machine

High-speed mold opening and closing

Strong power output, fast mold opening and closing, shortening production cycle.

Precise Clamping Unit

Standard with intelligent opening and closing mold program, opening mold position accuracy is improved, conducive to the manipulator to take products

Tailor-made Tie Bar

The special processing of the tiebar thread can greatly reduce the risk of the tie-bar breaking.

Reliable hydraulic lines

Flaring flange type pipeline, the whole machine pipeline is not welded, eliminating the risk of high pressure oil leakage due to welding

Quick response capability

Double-cylinder balanced injection device, supported by low-friction linear guide rails, guaranteeing maximum injection speed of 400mm/s.

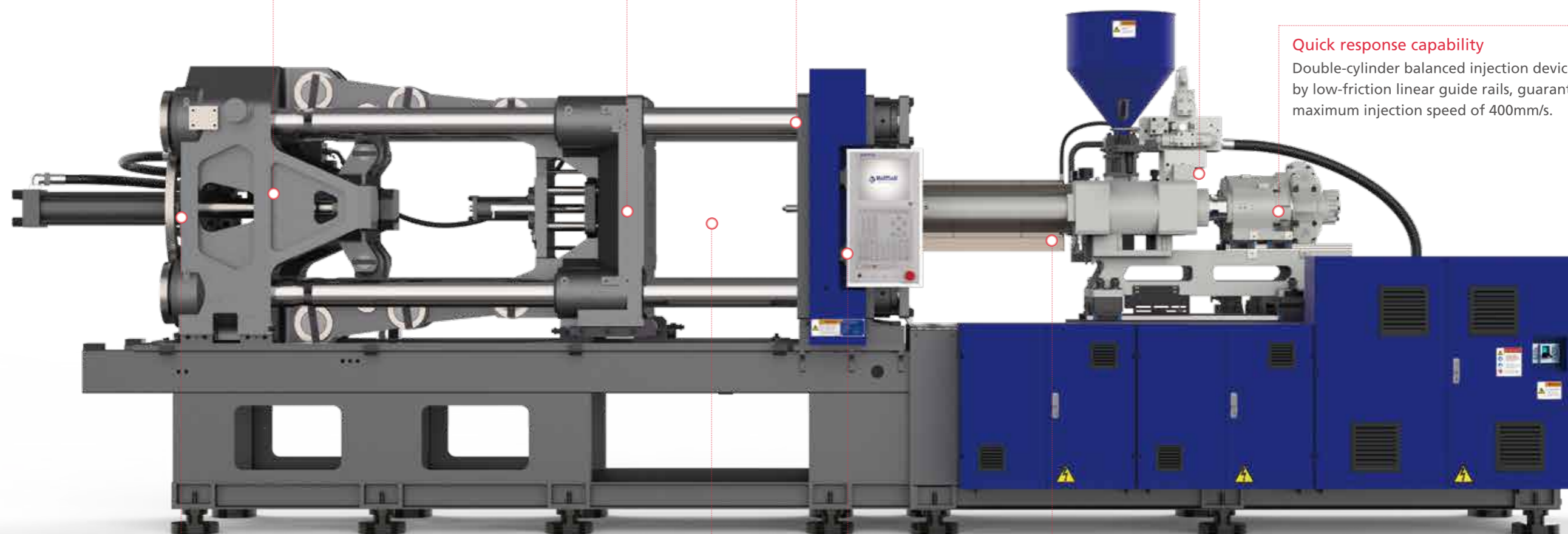

Reliable mold height adjusting mechanism

New mechanism, more balanced mold height adjustment gap control, reduced mold opening and closing impact, improved wear resistance, and convenient later maintenance.

Pressure center design

The mold locking force is directed to the center of the mold, the deformation of the template is reduced, and the strength is improved.

Efficient energy saving technology

Using infrared high-efficiency energy-saving heating device, heating faster and more energysaving.

Large screen color controller

12-inch Haitian dedicated controller, more comprehensive information display.

High-Speed and High Strength
Injection unit / Clamping unit



Optimum Design of Injection Unit

The twin-cylinder balanced injection unit is equipped with a low-resistance injection cylinder, excellent control system, reliable positioning accuracy, as well as high-speed and high response capabilities. In order to optimize the plasticizing system, a special screw with high plasticizing ability is used to ensure that the melt maintains high quality standards.



Easy to install mold cooling water pipe

The moving platen is equipped with mold cooling water distribution manifolds, which is convenient for customers to connect the mold water, and can expand the number of cooling water groups according to customer requirements

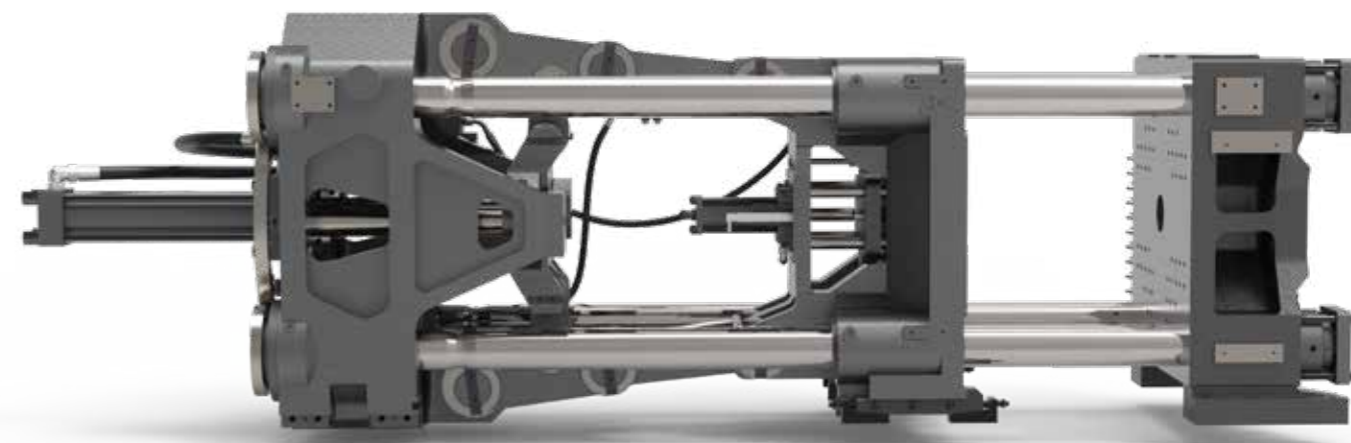

Platen Structure with High Rigidity

High rigidity of platen ensures that platen deformation is greatly reduced. The structural design of tie bar with special process can greatly delay the fracture risk under high cycle fatigue, Mechanical parts are durable.

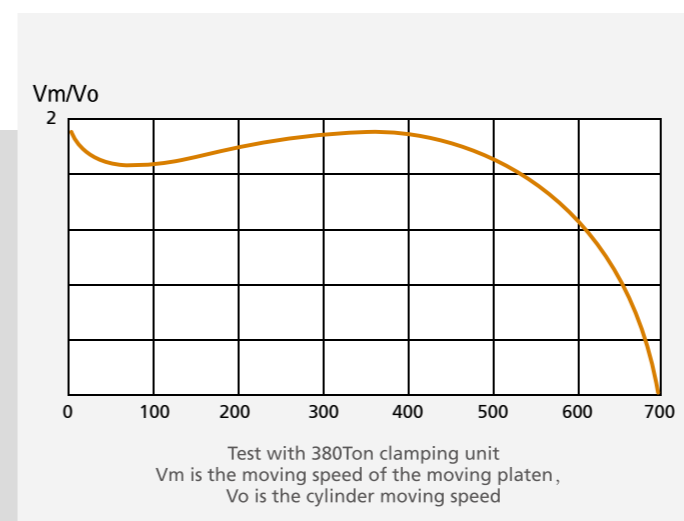

MA/H PRO series toggle motion curve

The newly designed toggles move faster; The mechanism is more stable; Better controllability; Dry cycle is shortened.

Data Analysis

Low Energy Consumption and High Performance

Comparison of Injection Speed

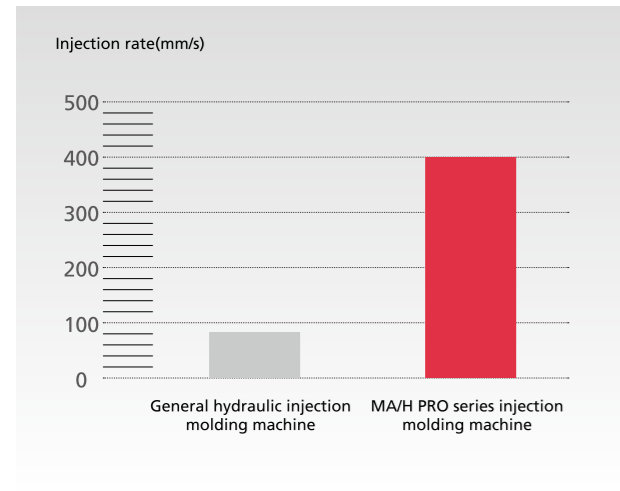

Supported by new servo motors and redesigned gear pumps, the maximum injection speed of the MA/H PRO is more than 400 mm/s. Through optimized hydraulic output, the injection process is stable and controllable.

Stress Analysis of Platen

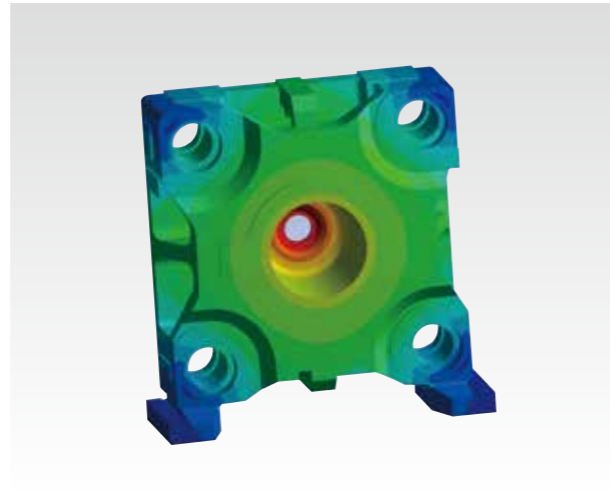

The newly designed platen is specially engineered for packaging products. The finite element software analysis shows that the average deformation is reduced by more than 30% compared to a normal hydraulic injection molding machine, effectively improving the precision of the products.

Comparison of Power Consumption

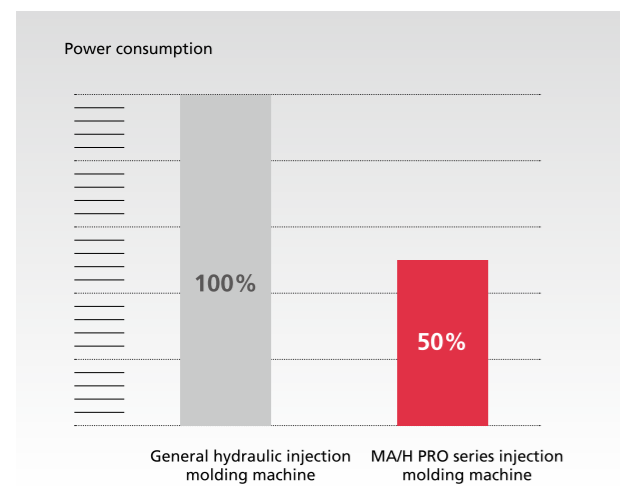

The mature servo drive technology is equipped with low friction design of injection components, and through the configuration of nano-efficient energy-saving heating device, the customer can save more energy, compared to the traditional vane pump machine energy efficiency of 50%.

High response hydraulic drive technology.



The new servo motor with low inertia is equipped with high speed hydraulic pump to provide better acceleration response performance. It provides stable and reliable hydraulic driving force for injection, opening and closing mold and other actions. The perfect combination of economy and performance.

High precision control system

Powerful computing ability

Equipped with powerful computing power of high performance controller, 12 inch color LCD screen, with universal USB interface, can be built to store multiple sets of mold data.

Enrich software functions

With the accumulation of plastic processing industry for many years, we can quickly enter your personalized needs, intuitive operation and optimization, so as to reduce the cost of equipment use.

Intelligent algorithm for mold open/close

The optimized design of the toggle system with the intelligent opening and closing mold program, the controller automatically collects the opening and closing mold data, the fuzzy operation makes the platen move more quickly and smoothly, the positioning is accurate, and the controllability is greatly improved.



Integrated Go-factory

Optional Go-factory function, the injection molding machine and peripheral auxiliary equipment is closely linked, forming a whole to realize the data acquisition and monitoring of auxiliary equipment.

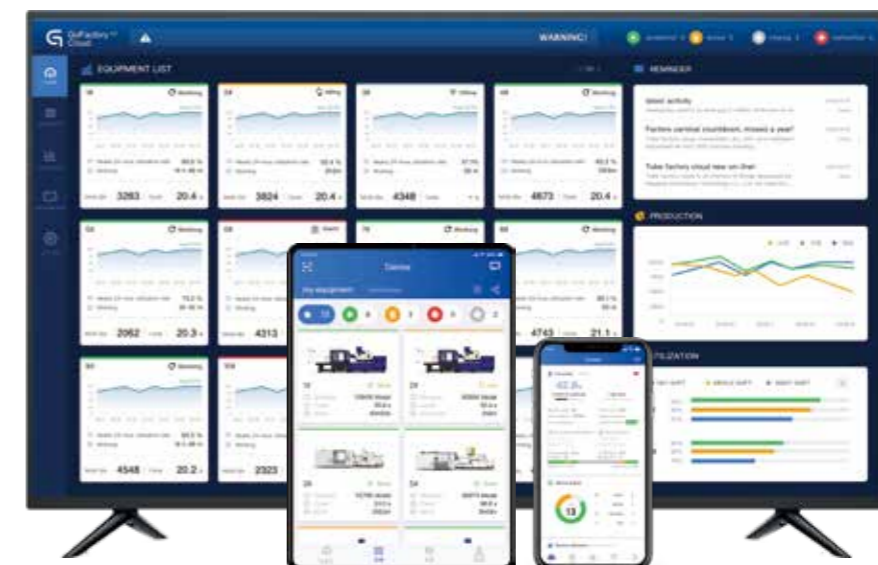

Thin-walled packing products

Applications



Application: Ice cream cup

Machine: MA2700H/780PRO
Raw materials: PP
Mold cavity: 6
Unit weight: 7.2g
Cycle time: 5.0s



Application: Milk tea cup

Machine: MA4500H/1280PRO
Raw materials: PP
Mold cavity: 8
Unit weight: 21.0g
Cycle time: 7.0s



Application: Lunch box

Machine: MA4500H/1280PRO
Raw materials: PP
Mold cavity: 4
Unit weight: 25.2g
Cycle time: 6.2s



Application: knife, fork and spoon

Machine: MA3200H/980PRO
Raw materials: PP
Mold cavity: 56
Unit weight: 3.7g
Cycle time: 12.0s



Application: PS cup

Machine: MA3200H/780PRO
Raw materials: PS
Mold cavity: 4
Unit weight: 12.5g
Cycle time: 8.6s



Application: Storage box

Machine: MA3800H/980PRO
Raw materials: PP+color master batch
Mold cavity: 2
Unit weight: 118.0g
Cycle time: 12.4s



Technical Parameters 2,100-3,200kN

		MA2100H/PRO	MA2700H/PRO		MA3200H/PRO	
INJECTION UNIT		580	780	980	780	980
Screw diameter	mm	45	50	55	50	55
Screw L/D ratio	L/D	25	25	25	25	25
Injection volume (theoretical)	cm ³	333	471	617	471	617
Injection weight (PS)	g	303	428	562	428	562
Injection pressure	MPa	168	188	184	188	184
Plasticizing rate (HDPE) ①	g/s	51.5	63.7	80.6	63.7	80.6
Injection rate (PS)	g/s	586	661	952	661	952
Injection speed	mm/s	405	370	440	370	440
Screw speed	rpm	0-300	0-300	0-300	0-300	0-300
CLAMPING UNIT						
Clamping force	kN	2100	2700		3200	
Mold movement stroke	mm	490	560		560	
Dist. between tie bars (HxV)	mm	520x520	560x560		620x620	
Mold height max.	mm	550	600		600	
Mold height min.	mm	200	220		220	
Ejection stroke	mm	120	150		150	
Ejector force	kN	62	62		62	
OTHERS						
System pressure	MPa	21	21	21	21	21
Pump motor power	kW	40	53	40+40	53	40+40
Heater power	kW	18.8	23.5	28.5	23.5	28.5
Machine dimension (LxWxH)	m	6.3x1.7x2.4	6.6x1.9x2.5	6.6x1.9x2.5	6.7x1.9x2.5	6.7x1.9x2.5
Machine weight	t	9.5	11.5	11.9	12.5	12.9
Hopper capacity	kg	50	50	50	50	50
Oil tank	l	390	440	530	440	530

Platen dimensions

Moving platen

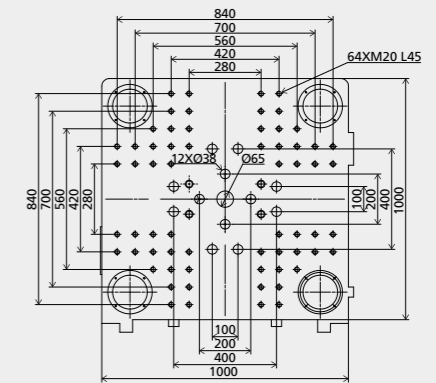
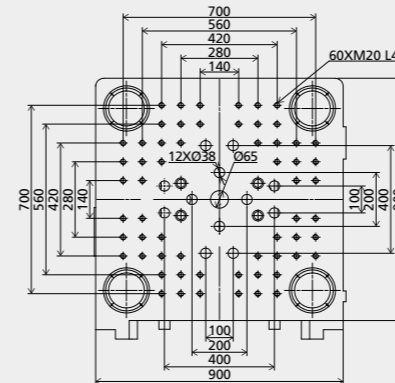
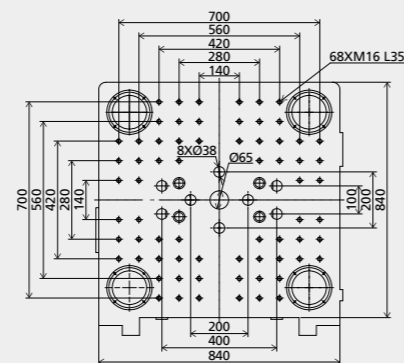

Platen dimensions②

Mounting hole for robot/sprue picker top view from fixed platen

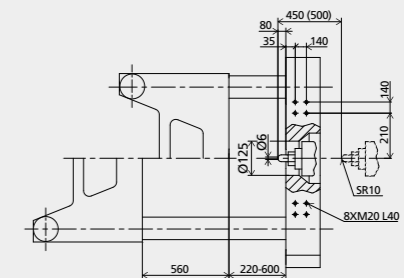
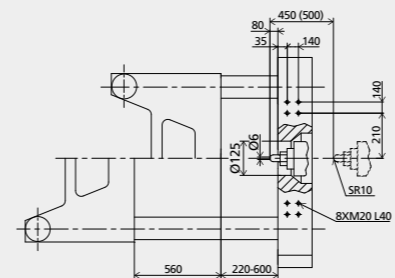
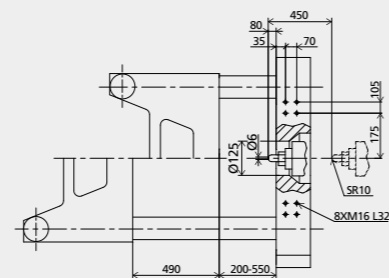

Machine dimensions②

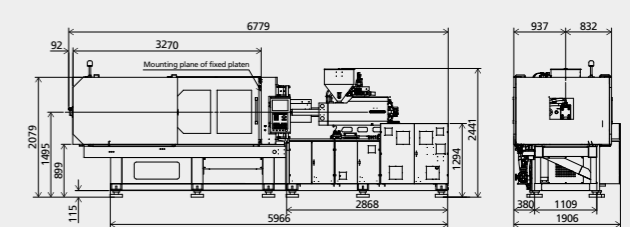
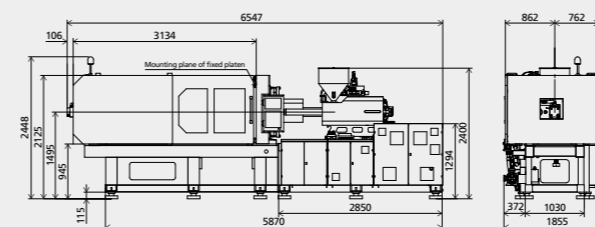
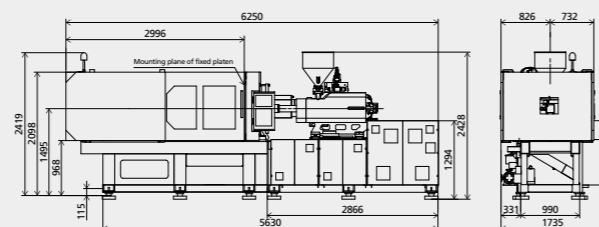

Note:

①Plasticizing capacity (HDPE): Equipped with plasticizing components of standard packaging machine, tested according to Euromap 19.

②Value in "()" is the size of bigger injection unit.

The Company reserves the right to modify technical parameters without prior notice.

Technical Parameters 3,800-4,500kN

		MA3800H/PRO		MA4200H/PRO		MA4500H/PRO	
INJECTION UNIT		980	1280	980	1280	980	1280
Screw diameter	mm	55	60	55	60	55	60
Screw L/D ratio	L/D	25	25	25	25	25	25
Injection volume (theoretical)	cm ³	617	791	617	791	617	791
Injection weight (PS)	g	562	720	562	720	562	720
Injection pressure	MPa	184	180	184	180	184	180
Plasticizing rate (HDPE) ①	g/s	80.6	102.7	80.6	102.7	80.6	102.7
Injection rate (PS)	g/s	952	1093	952	1093	952	1093
Injection speed	mm/s	440	425	440	425	440	425
Screw speed	rpm	0-300	0-280	0-300	0-280	0-300	0-280
CLAMPING UNIT							
Clamping force	kN	3800		4200		4500	
Mold movement stroke	mm	700		700		720	
Dist. between tie bars (HxV)	mm	670x670		690x690		760x730	
Mold height max.	mm	710		710		750	
Mold height min.	mm	300		300		300	
Ejection stroke	mm	160		160		160	
Ejector force	kN	110		110		110	
OTHERS							
System pressure	MPa	21	21	21	21	21	21
Pump motor power	kW	40+40	40+40	40+40	40+40	40+40	40+40
Heater power	kW	28.5	30.9	28.5	30.9	28.5	30.9
Machine dimension (LxWxH)	m	7.4x2.0x2.5	7.4x2.0x2.5	7.5x2.0x2.5	7.5x2.0x2.5	7.9x2.1x2.6	7.9x2.1x2.6
Machine weight	t	17.3	17.6	18.9	19.2	22.5	22.8
Hopper capacity	kg	50	50	50	50	50	50
Oil tank	l	580	580	580	580	580	580

Platen dimensions

Moving platen

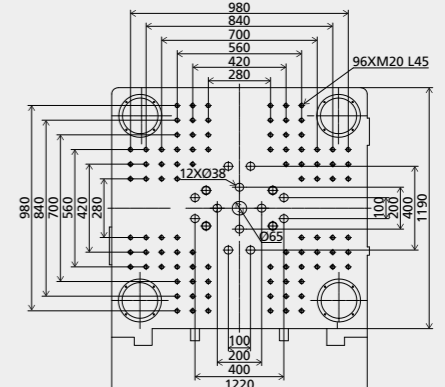
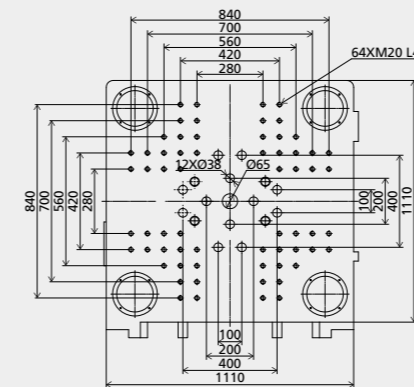
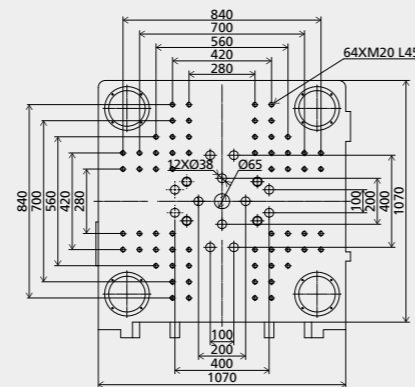

Platen dimensions②

Mounting hole for robot/sprue picker top view from fixed platen

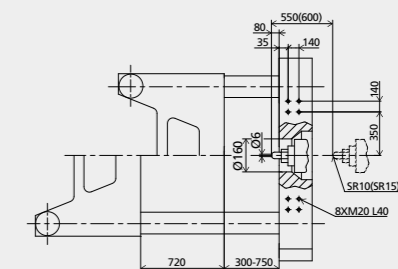
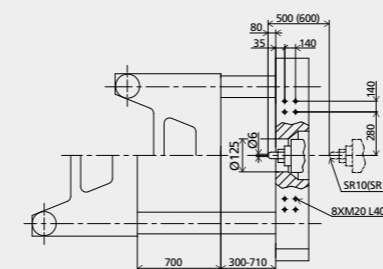
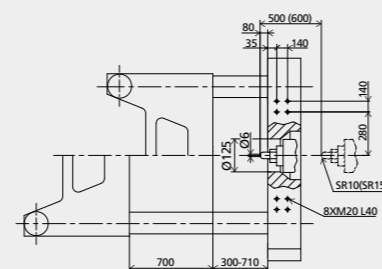

Machine dimensions②

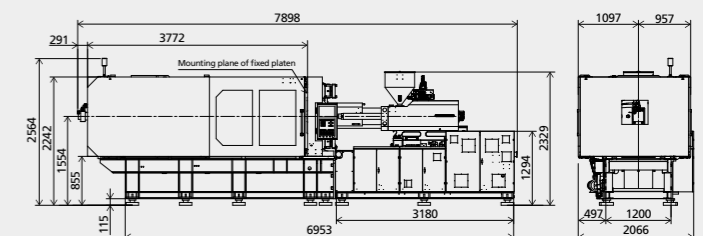
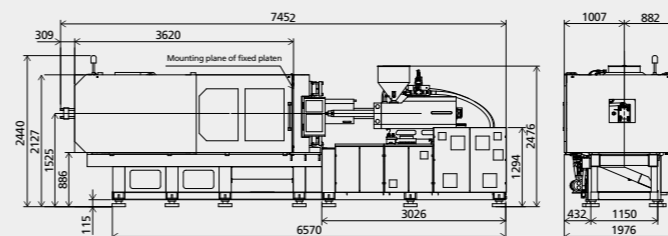
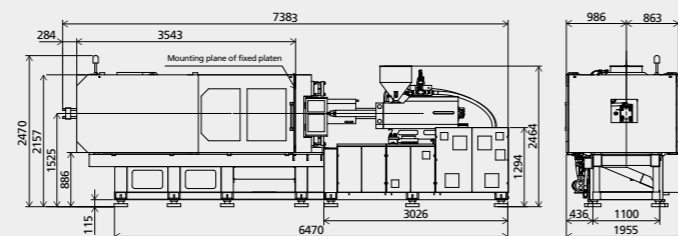

Note:

①Plasticizing capacity (HDPE): Equipped with plasticizing components of standard packaging machine, tested according to Euromap 19.

②Value in "()" is the size of bigger injection unit.

The Company reserves the right to modify technical parameters without prior notice.